



# AL175ULB

## Access Control Power Supply/Charger

### Overview:

AL175ULB is a power-limited power supply/charger that converts a 24VAC input into two (2) individual PTC protected auto-resettable 12VDC or 24VDC outputs (see specifications). They are intended for use in applications requiring UL Listing for Access Control (UL 294) and applications requiring an interface with Fire Alarm Control Panels.

### Specifications:

#### Agency Listings:

- UL Recognized component for Access Control Systems (UL 294).



#### Input:

- Input 24VAC, 40VA from UL Listed, Class 2 transformer.
- Fire Alarm Panel or Access Control trigger input.

#### Output:

- 12VDC or 24VDC selectable outputs.
- 12VDC @ 1.75A or 24VDC @ 0.9A supply current.
- Two (2) Class 2 Rated power-limited outputs.
  - Fail-Safe/Fail-Secure lock output (switched).
  - Auxiliary power output (unswitched).
- PTC protected outputs, rated @ 2.5A.
- Filtered and electronically regulated output\*.
- Short circuit and thermal overload protection.

#### Battery Backup:

- Built-in charger for sealed lead acid or gel type batteries.
- Automatic switch over to stand-by battery when AC fails.
- Maximum charge current 0.4A.

#### Supervision:

- AC fail supervision (form "C" contacts).
- Supervised Fire Alarm Disconnect (Latching w/reset or Non-Latching).

#### Visual Indicators:

- AC input and DC output LED indicators.

#### Board Dimensions (L x W x H approximate):

5.25" x 3.0" x 1.4" (133.4mm x 76.2mm x 35.6mm).

\*Note: When unit is powered by battery backup (AC Fail condition), the rated voltage at DC OUT output is Unregulated. Its Rated Voltage is as follows: AUX: (11.7V – 13.2V)/(23.75V – 26.4V) @ Rated Current 1.75A.

#### ANSI/UL 294 8th Ed. Access Control Performance Levels:

Destructive Attack: I; Endurance: IV; Line Security: I; Stand-by Power: IV

### Power Supply Output Specifications:

Output VDC	Switch Position	Max. Stand-by Load DC	Max. Alarm Load DC	Battery (optional)
12VDC	SW1 OFF	1.75A	1.75A	12VDC
24VDC	SW1 ON	0.9A	0.9A	24VDC

### Stand-by Specifications:

Output	4 hr. of Stand-by & 5 Minutes of Alarm
12VDC / 7AH Battery	Stand-by = 1.25A Alarm = 1.25A
24VDC / 7AH Battery	

### Installation Instructions:

AL175ULB should be installed in accordance with article 760 of The National Electrical Code or NFPA 72 as well as all applicable Local Codes and Regulations. Product is intended for indoor use only.

See Terminal Identification Chart on page 3 for a description of each terminal function.

1. Mount AL175ULB in the desired location/enclosure (mounting hardware included).
2. Connect 28VAC, 40VA transformer to the terminals marked [AC AC]. Use 18 AWG or larger for all power connections (Battery, DC output). Use 22 AWG to 18 AWG for power-limited circuits (trigger inputs, dry outputs).

**Keep power-limited wiring separate from non power-limited wiring (115VAC / 60Hz Input, Battery Wires). Minimum 0.25" spacing must be provided.**

3. Set the AL175ULB to the desired DC output voltage by setting switch SW1 to the appropriate position (see Power Supply Output Specification Chart, above).

**CAUTION: Do not touch exposed metal parts.**

**Shut branch circuit power before installing or servicing equipment.**

**There are no user serviceable parts inside. Refer installation and servicing to qualified service personnel.**

4. Measure output voltage before connecting devices. This helps avoiding potential damage.

5. Connect battery to the terminals marked [+ BAT -] on the unit (battery leads included).

Use two (2) 12VDC batteries connected in series for 24VDC operation.

**Note:** For Access Control applications batteries are optional.

When batteries are not used, a loss of AC will result in the loss of output voltage.

When the use of stand-by batteries is desired, they must be lead acid or gel type.

6. Connect appropriate signaling notification devices to AC Fail supervisory relay outputs.

**Note:** To meet UL requirements, AC Supervisory outputs must be connected to the zone of Alarm Control Panel or to visual AC trouble indicator.

7. For Access Control Device & Fire Alarm Interface connections see *Application Diagrams, pg. 3 - 4.* and *Terminal Identification Chart, pg. 2.*

Fig. 1

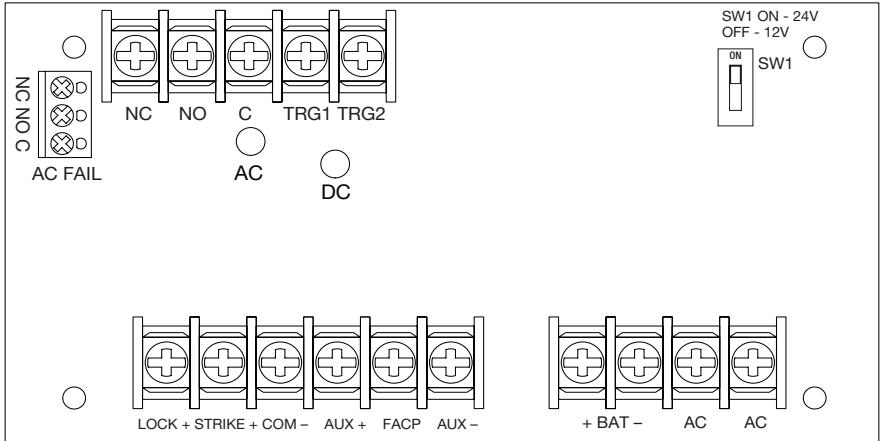

### Terminal Identification:

Terminal Legend	Function/Description
AC	Low voltage AC input.
TRG1 & TRG2	These input terminals are designed to connect to the normally closed outputs of an access control or fire alarm relay. These terminals control [LOCK+], and [STRIKE+], as well as AL175ULB output relay contacts [N.C., N.O., C]
LOCK +	This terminal provides DC output voltage when [TRG1] and [TRG2] are shorted together and are typically used to power Mag Locks.
STRIKE +	This terminal provides DC output voltage when [TRG1] and [TRG2] are unshorted and are typically used to power Electric Strikes.
N.C., N.O., C	Isolated dry Form "C" contacts. Shorting [TRG1] and [TRG2] together causes these contacts to switch. They are typically used for controlling multiple AL175ULBs with fire alarm tie-in (Fig. 4, pg. 3 and Fig. 5, pg. 4).
AUX +	Continuous positive (+) DC power output voltage. It is not affected by TRG1, TRG2 operation.
COM -	Common negative (-) output (ground).
FACP	Spare wiring terminal used for fire alarm tie-in application (Fig. 4, pg. 3).
+ BAT -	Stand-by battery connections.
AC Fail N.C., C, N.O.	Used to notify loss of AC e.g connect audible device or alarm panel relay normally energized when AC power is present. Contact rating 1A @ 28VDC.

## LED Diagnostics:

Red (DC)	Green (AC)	Power Supply Status
ON	ON	Normal operating condition.
ON	OFF	Battery backup is powering output.
OFF	ON	No DC output.
OFF	OFF	Loss of AC. Discharged or missing stand-by battery. No DC output.

## Maintenance:

Unit should be tested at least once a year for the proper operation as follows:

**Output Voltage Test:** Under normal load conditions the DC output voltage should be checked for proper voltage level (**Power Supply Output Specifications Chart**).

**Battery Test:** Under normal load conditions check that the battery is fully charged, check specified voltage both at the battery terminal and at the board terminals marked [+ BAT -] to ensure that there is no break in the battery connection wires.

**Note:** Maximum charging current under discharge is 400mA.

**Note:** Expected battery life is 5 years; however, it is recommended changing batteries in 4 years or less if needed.

## Typical Application Diagrams:

Fig. 2

Typical single mag lock or door strike installation with fire alarm tie-in using trigger controlled output.

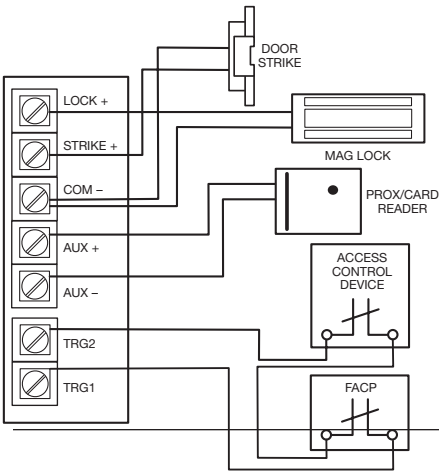
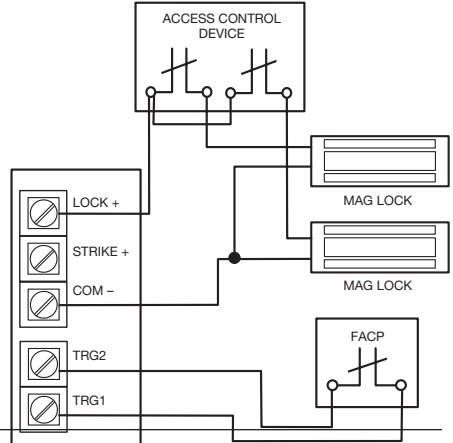

Fig. 3

Typical dual mag lock installation with fire alarm tie-in using trigger controlled outputs:



## Typical Application Diagrams:

Fig. 4 - Typical mag lock with fire alarm tie-in using aux output installation:

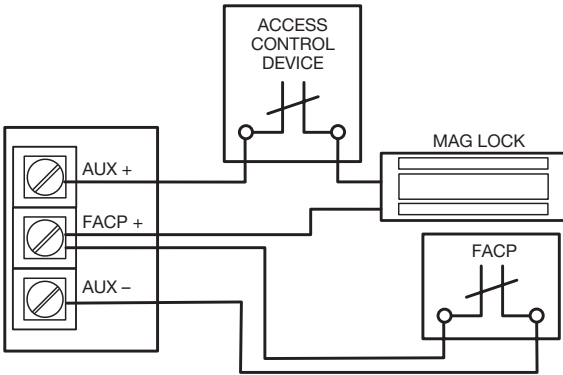

Fig. 5 - Latching fire alarm tie-in with manual reset:

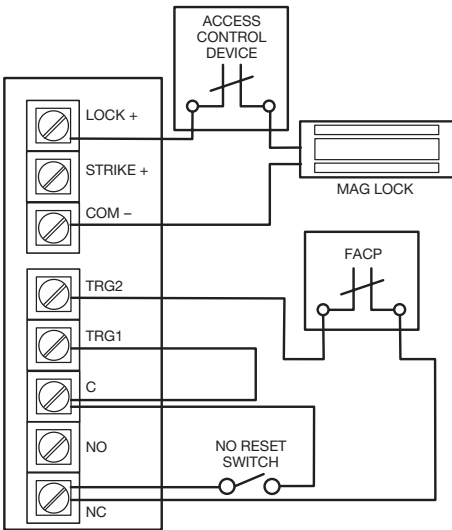
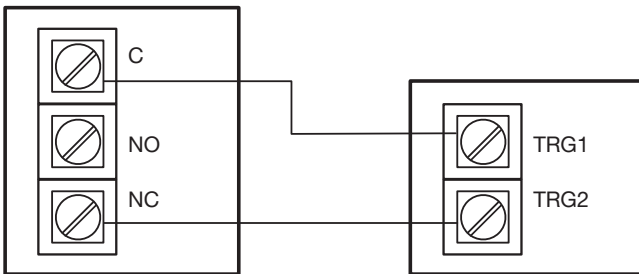

Fig. 6 - Multiple AL175ULB power supply connections:



Altronix is not responsible for any typographical errors.

140 58th Street, Brooklyn, New York 11220 USA | phone: 718-567-8181 | fax: 718-567-9056  
 website: [www.altronix.com](http://www.altronix.com) | e-mail: [info@altronix.com](mailto:info@altronix.com) | Lifetime Warranty  
 IIAL175ULB - Rev. 081601 J30X

